

# One Weekend ACTIVITIES

## Making and Installing Plywood Shutters

*If your home is not protected by impact-resistant windows and doors or impact-resistant shutters or panels, consider building your own temporary emergency panels.*

### Step One: Assemble Your Tools and Hardware.

Tools you will need:

- Tape Measure
- Circular saw
- Drill and drill bits
- Hammer
- Wrench
- Work gloves
- Safety goggles

Hardware you will need:

- Bolts
- Wood or masonry anchors
- Nuts and large washers

*Note: A range of bolts may be used because different bolts will be needed for wood frame versus masonry homes. Wood homes use lag screws and plastic coated permanent anchors. Masonry homes use expansion bolts and galvanized permanent expansion anchors.*

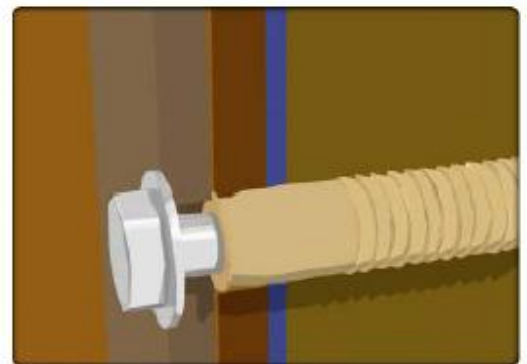

### Notes

---

---

---

---

---

---

---

---

---

---



# One Weekend ACTIVITIES

## Step Two: Plan the Project

- Count and measure each window and door that has glass including French doors, sliding glass doors as well as skylights. You might also want to include roof and gable end vents or any opening that if damaged would allow wind to enter your home.
- Measure each opening horizontally inside the exterior trim and vertically from the sill to the bottom of the top trim.
- Add eight inches to both the height and width to provide a four-inch overlap on all sides.
- When measuring a window with an extended sill measure from the top of the sill to the top of the window and add four inches instead of eight.
- Sheets of plywood are generally 4 feet by 8 feet. This will help determine how many sheets to buy. Be sure to purchase plywood that is 5/8 inch or greater, exterior grade (CDX).

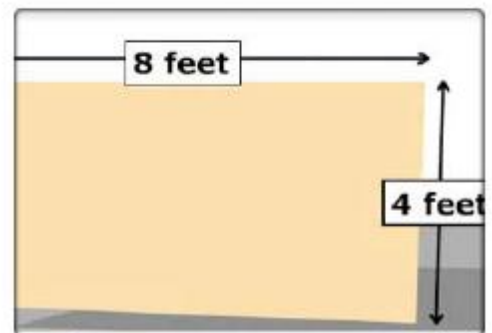
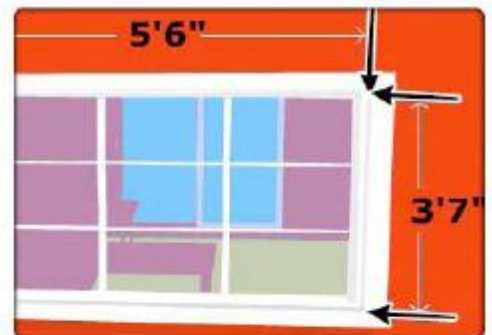

## Notes

---

---

---

---

---

---

---

---

---

---



# One Weekend ACTIVITIES

## Step Three:

- First drill holes in the same diameter as the bolts or screws, 2 inches in from the edges of the plywood at each corner and at 12 inch intervals around the panel.
- Next hold the plywood firmly in place over the opening to mark where to drill mounting holes.
- If the window sill is flush to the wall, secure the plywood on all four sides.
- If the window sill extends out at the bottom, secure the plywood on the top and sides.
- For windows 3 feet by 4 feet or smaller installed on a wood frame house, use 1/4-inch lag screws and plastic coated permanent anchors.
- The lag screws should penetrate the wall and frame surrounding the window at least 1 ¾ inches. For larger windows, use 3/8 inch lag screws that penetrate the wall and frame surrounding the window at least 2 ½ inches.

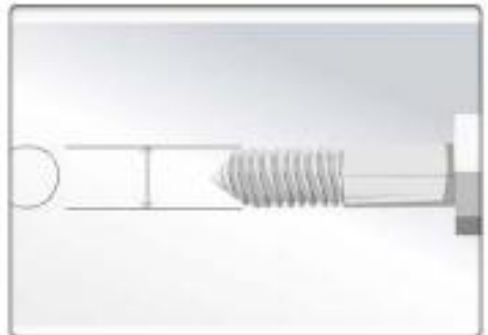

## Notes

---

---

---

---

---

---

---

---

---

---



# One Weekend ACTIVITIES

## Step Three (cont.):

- For windows 3 feet by 4 feet or smaller installed on a masonry house, use 1/4 inch expansion bolts and galvanized permanent expansion anchors.
- The expansion bolts should penetrate the wall at least 1 ½ inches. For larger windows, use 3/8-inch expansion bolts that penetrate the wall at least 1 ½ inches.
- If a window or door is larger than a sheet of plywood, you will need to join the panels with 2X4 bracing along the entire seam.
- Attach the 2X4s to the outside of the plywood panel with 10 gauge, 2 inch long galvanized screws (exterior deck screws) spaced every 4 inches.
- Use the widest side of the 2X4 to run the length of the entire seam.

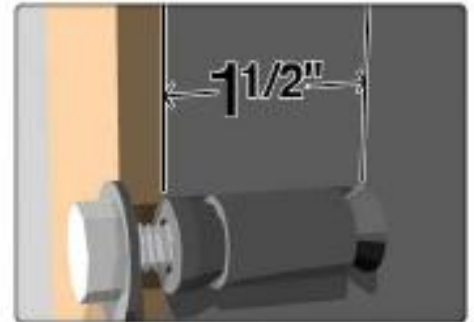

## Notes

---

---

---

---

---

---

---

---

---

---

# One Weekend ACTIVITIES

## Step Four: Finishing Up

- When you're done, mark each panel with the name of the opening so you will quickly know where to install it when a storm is approaching.
- Store the panels, washers and nuts together in a location away from the elements.
- Consider waterproofing the panels with paint or a sealant.

Be sure to visit [flash.org](http://flash.org) for more information about strengthening your home and safeguarding your family from disaster.



## Notes

---

---

---

---

---

---

---

---

---

---

